



# SYSTEMS FOR MACHINE VISION **The Challenge of Complexity.**



# The Challenge of Complexity.

We see complexity as the fusion of challenging tasks with intelligent solutions. We integrate light and innovative technology for a new standard of systems performance. This is our key to unlocking what lies seemingly hidden.

We as technology leader develop, produce and globally distribute an optimally complementing, modular system of complex image processing systems such as vision sensors, intelligent cameras and multi-camera systems to a standard of exactitude that optimally complements our individual high-performance LED lighting and precision optics.

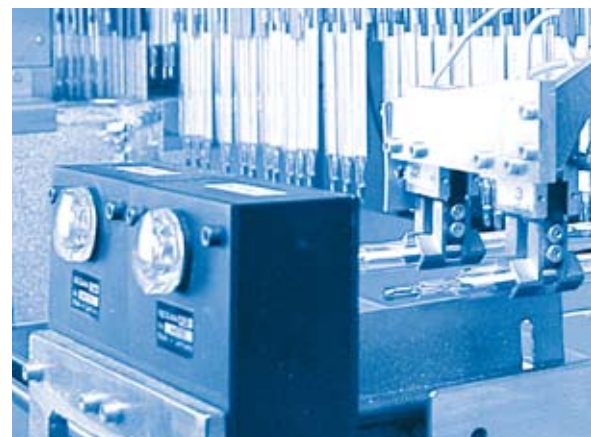
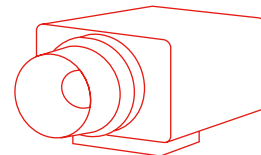
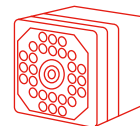

# FOR EVERY APPLICATION THE RIGHT PERFORMANCE.

VISION SENSORS • INTELLIGENT CAMERAS • MULTI-CAMERA SYSTEMS

Our extensive product range of machine vision systems – from vision sensors to high-end image processing systems – offers you precisely the flexibility and performance you require for your specific image processing tasks. All systems are also supported by our graphic operating software *vcwin®*, guaranteeing that you can quickly parameterise and successfully implement your application.

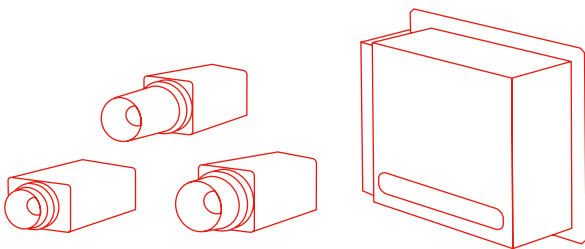

## Security through Quality:

Besides of complex systems for machine vision our component system also consists of precision lenses and individually powerful lighting units, allowing you to select the right components for your task and optimally configure your image processing system.

## All our systems are characterized by :

- Fast assembly and set-up
- Easy operation and parametrisation
- Safe real-time operation in industrial use
- Reliable performance and long life cycles
- High quality standards and delivery reliability
- Worldwide availability

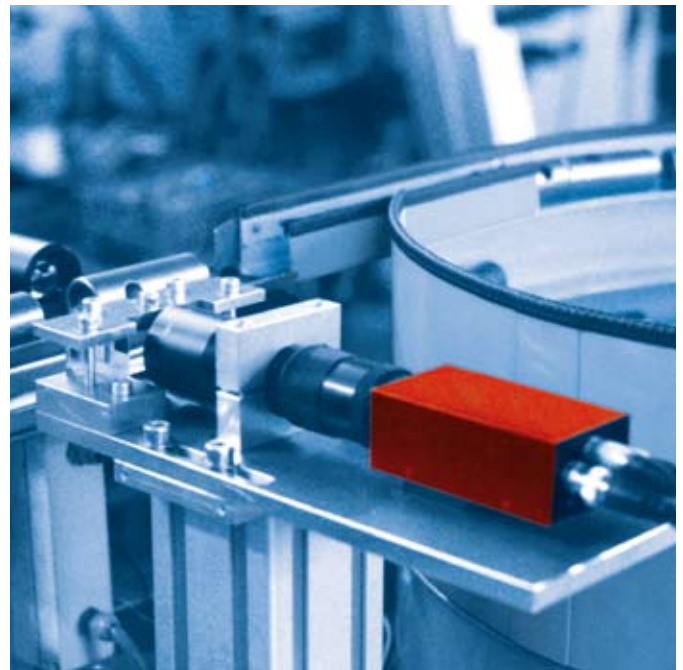



## camat®

### Vision Sensors – compact and fast

camat® vision sensors are optimised for specific image processing tasks, easy to use and fast to parameterise.

- **„All-in-One“ design**  
through integrated precision lens, powerful LED lighting, image acquisition and processing electronics as well as communication interface
- **Precise measuring results**  
through the use of high-resolution image sensors
- **„Auto-Teach-In“**  
for easy customisation to your application
- **Fast image processing**  
through optimised algorithms and powerful digital signal processor (DSP)
- **Fast process and USB2.0 interface**  
industry-standard conform digital in-/outputs (4/4), RS232
- **Compact IP67 version**  
for use under industrial conditions



## pictor®

### Intelligent Cameras – small and powerful

Intelligent cameras from the pictor® series are perfectly suited to flexible application in solving complex image processing tasks.

- **Compact design**  
through integrated imaging sensor, digital signal processor (DSP) and process interface
- **Optimised for fast image acquisition and processing**  
up to 240 images/sec in real-time
- **Flexible utilisation**  
matrix and line scan cameras with CCD sensors, from VGA to 2 megapixels in monochrome and colour
- **Industry-standard conform process interface**  
digital in-/outputs (5/5), RS232, Ethernet, Profibus DP connection
- **Various communication protocols**  
for flexible data exchange
- **Easy Job selection and parameterisation**  
through keypad and monitor connection directly on the camera

# vicosys®

## Multi-Camera Systems – high performance and individually configurable

Individually extendable vicosys® multi-camera systems guarantee high performance in demanding applications.

- **Fast parallel image acquisition**  
via four channels with up to eight FireWire™ or CamerLink cameras
- **Different inspection views**  
through combination of various camera types: matrix and line scan, VGA up to eight megapixels, monochrome and colour

- **„Ready-for-Work“**  
pre-configured system is easy to take into operation
- **vicosys® SDK**  
for optimal integration of customer-specific image processing algorithms
- **Guaranteed and stable program execution**  
through single-task LINUX
- **Extended communication options**  
through digital in-/outputs (8/8), RS232, Gigabit-Ethernet, Profibus-DP

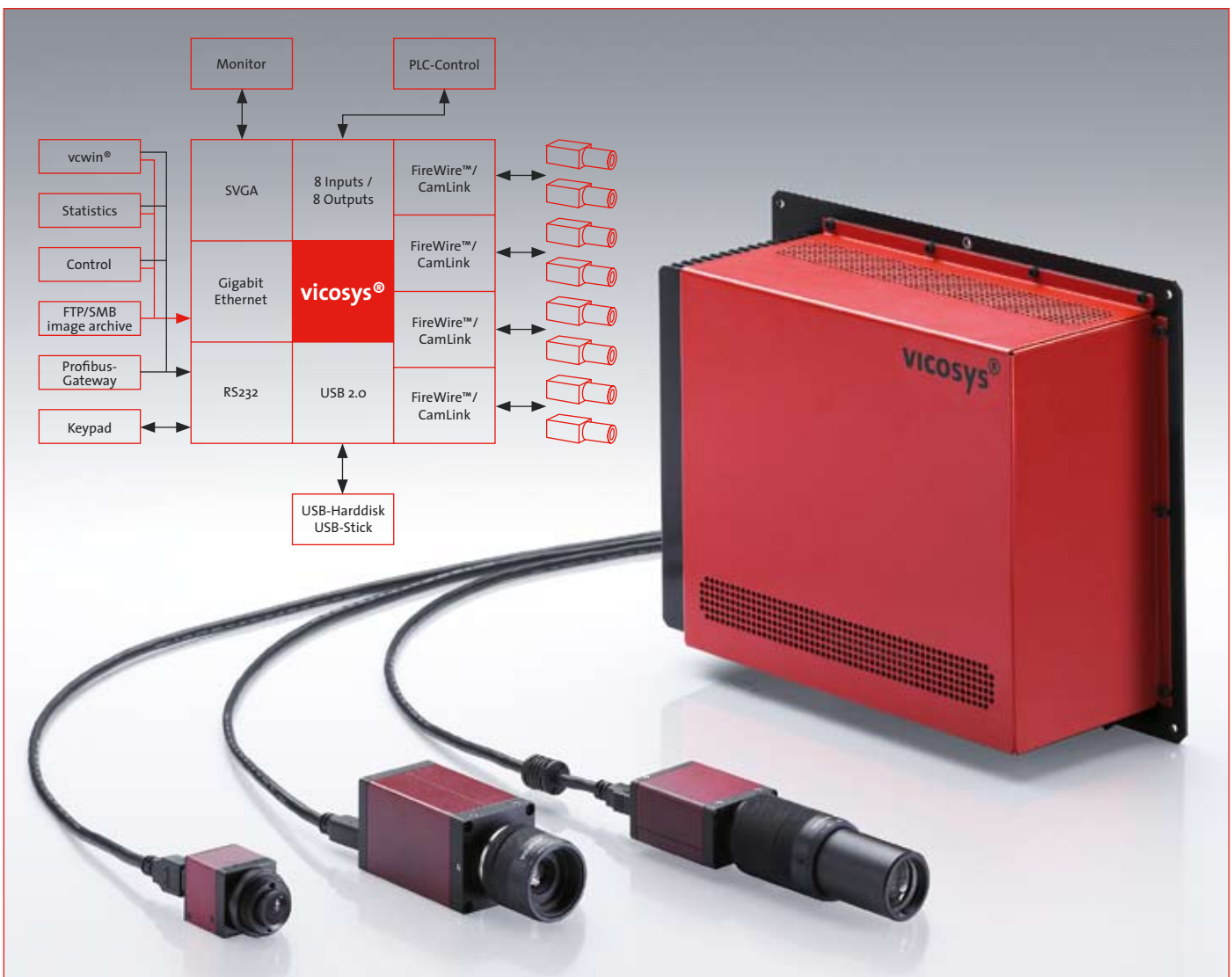

# THREE SYSTEMS – ONE OPERATING SOFTWARE.

**vcwin®**

To quickly solve both simple and complex machine vision tasks, we offer the vcwin® operating software. This graphic user interface is perfectly adapted to the camat®, pictor® and vicosys® systems.

It provides you with an extensive image processing library and enables easy use of its image processing tools with all three systems.

- **Powerful image processing tools – easy to parameterise for:**

- precise measuring
- proper checking for presence, position, location, completeness and characteristics
- reliable surface inspection and pattern recognition
- flexible colour image processing
- fast OCR/OCV and data matrix code reading

- **Reproducible image processing results**

even under difficult lighting conditions or with complex object structures

- **Flexible communication to the manufacturing process**

by supporting a wide range of protocols including process control, and the open **vicorem®** remote protocol

- **Extensive functionality**

for process control, measurement statistics and error logging during runtime

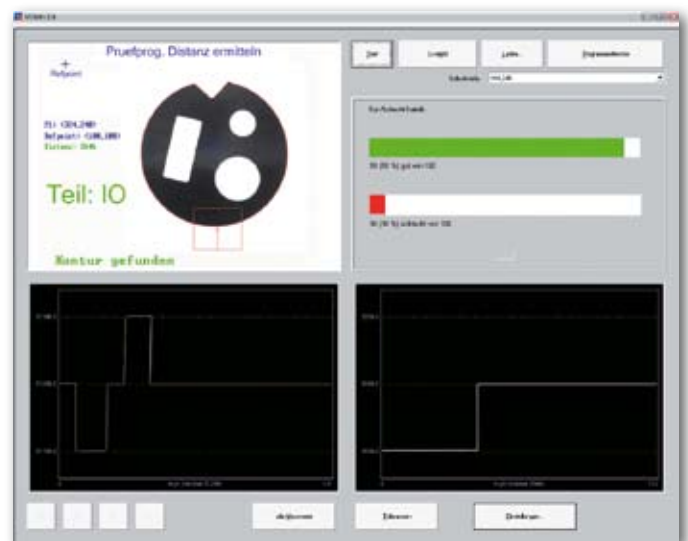
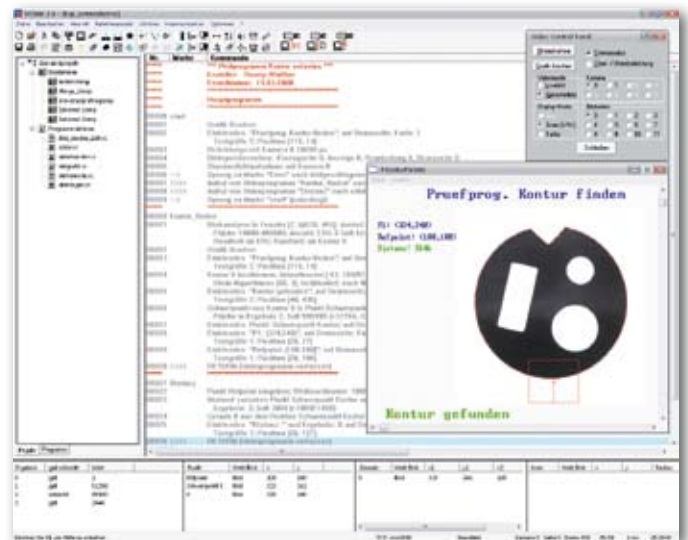

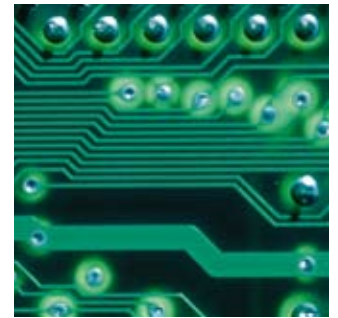
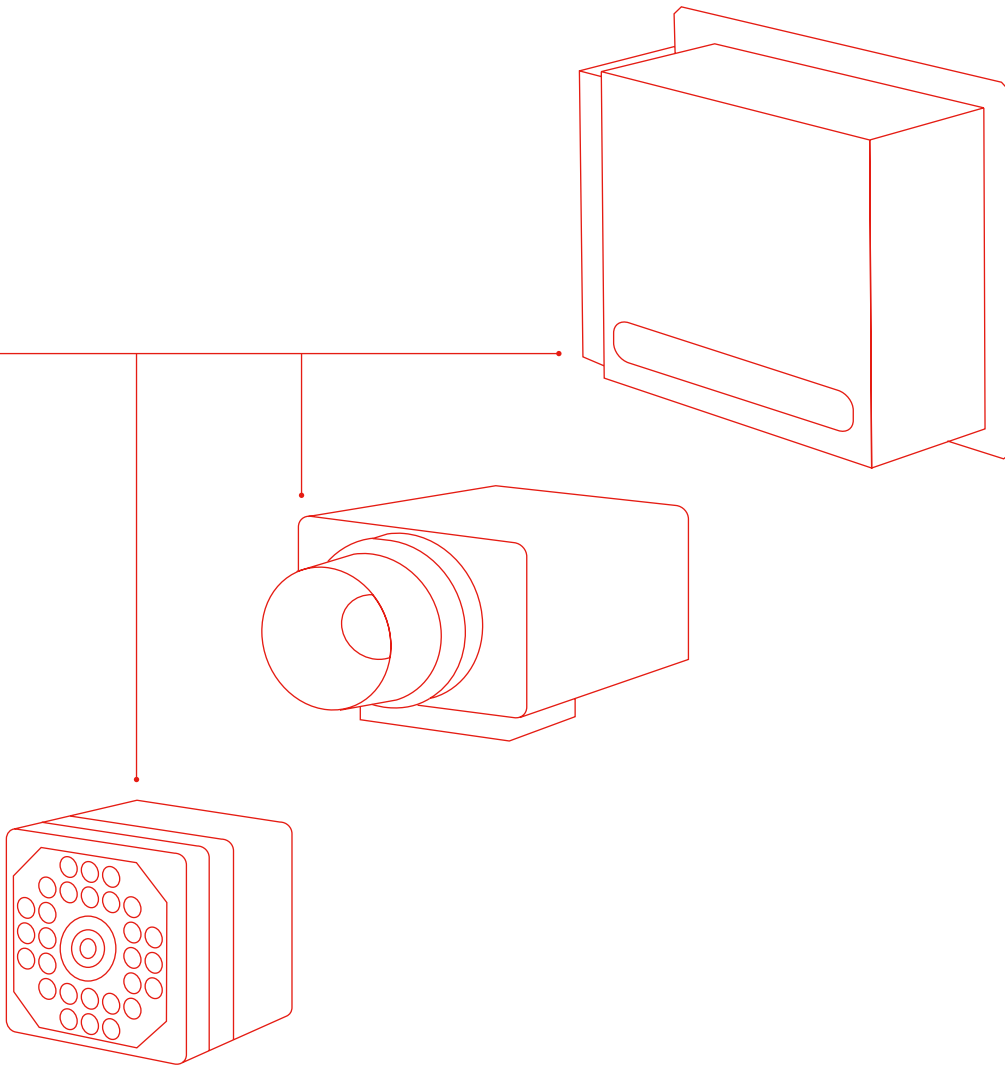

## RELIABILITY AND PRECISION:

Systems by Vision & Control have proven their value in thousands of different applications across a wide range of industries:

- Automotive
- Mechanical engineering
  - Electronics
  - Plastics industry
  - Printing industry
- Packaging industry
  - Robotics
  - Pharmaceuticals
  - Food industry

...



Vision & Control GmbH  
Mittelbergstraße 16  
98527 Suhl · Germany

Phone: +49 36 81 / 79 74-0  
Fax: +49 36 81 / 79 74-33

Current information, data sheets and 3D CAD data on our extensive portfolio of systems, lighting and optics for industrial image processing are available at

[www.vision-control.com](http://www.vision-control.com).

• **camat**® Vision Sensors

• **pictor**® Intelligent Cameras

• **vicosys**® Multi-Camera Systems

• **vcwin**® Operating Software

• **vicolux**® Lighting

• **vicotar**® Optics

**Individual configuration - optimal performance:  
The Vision & Control component system**

Experienced machine builders, OEMs and system integrators worldwide rely on components and systems by Vision & Control. Wherever flexibility, speed, reliability and suitability to industrial uses are highest priorities, our products are the first choice.

We guarantee competent consulting, convincing quality and best service.

Squids are optimally adapted to their environment. They achieve extremely high speeds and their specialised muscles give them great agility. Many deep-sea varieties can communicate with one another through colour changes and luminous organs.